

**TWO COMPARTMENT GREASE TRAP, 1000 GAL.
CITY OF SPRINGFIELD STD. - TRAFFIC LOADS**

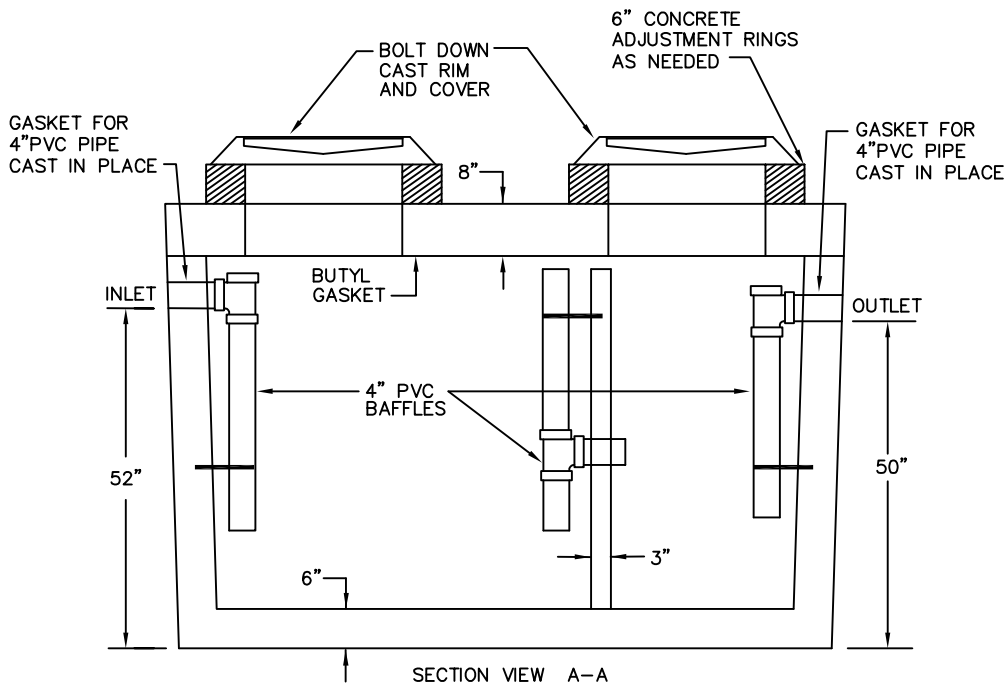

SPECIFICATIONS / STEWART CONCRETE STANDARDS
5000 PSI MINIMUM AT 28 DAYS
DESIGN MAXIMUM EARTH COVER IS 3.0'; TRAFFIC LOADS
BUTYL GASKET PROVIDED FOR JOINT

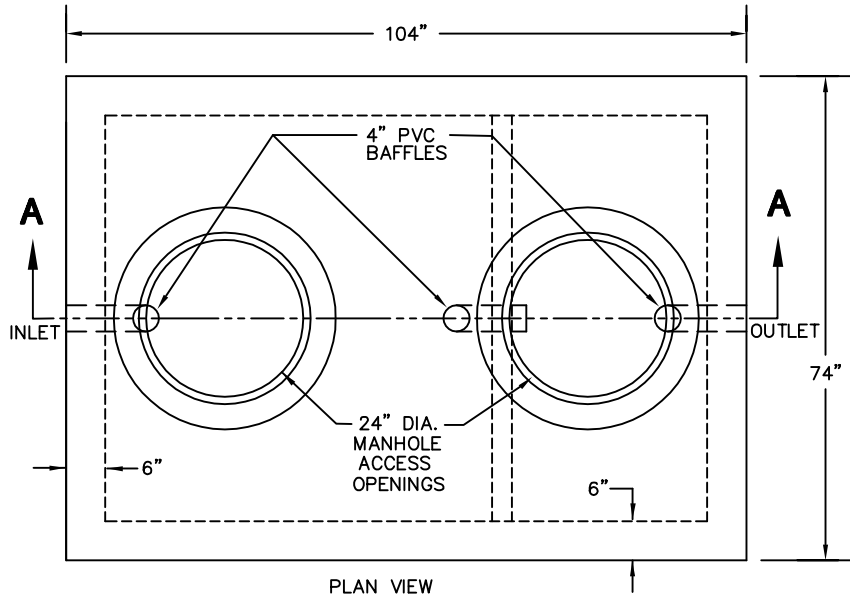

STEWART CONCRETE PRODUCTS
2179 HIGHWAY 32
HALFWAY, MISSOURI 65663
(800) 798-0183 FAX (417) 445-2681

www.stewartconcrete.net